

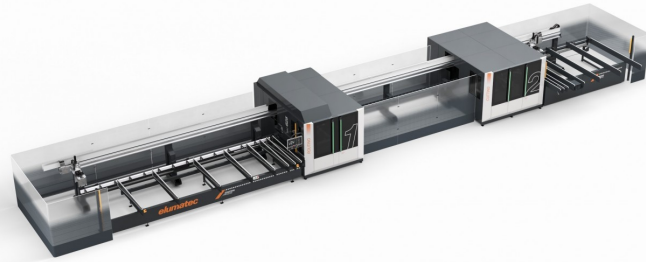

SBZ625/13

Machining centres



The state-of-the-art SBZ 625/13 automated pass-through centre gives users unrivalled precision and flexibility in aluminium machining. Equipped with up to 40 axes, the machining centre is durable and powerful thanks to its solid and robust design. It enables effortless machining of standard aluminium profiles and window and door profiles. Parallel machining steps significantly reduce production times, and the intuitive user interface makes it easy to use.

Parallel machining to accelerate production

Multiple operations can be performed at the same time on the SBZ 625/13, enabling faster results with fewer personnel. That's because the machining station and the saw, with a maximum part length of up to 7,500 mm, have been separated.

Redesigned user interface

The display is now responsive and web-based. Making interfaces transparent, understandable and intuitive was the top priority during development. Instant visualisation of machine and production data, as well as status and maintenance displays, gives users clear insights into production at all times.

Intelligent unloading station

The unloading system of the 625/13 offers a flexible, intelligent solution for unloading short and long parts. The outfeed conveyors enable efficient utilisation of the available space, protect surfaces and ensure safe transport and optimum handling of parts between 360 mm and 7,500 mm in length.



Integrated user interface

The clear 21" TFT display, Windows operating system and touchscreen make the SBZ 625/13 profile machining centre easy and intuitive to use. Detailed, easy-to-understand graphical representations improve communication between the operator and the machine.



Infeed loading magazine

Depending on the profile cross-section, the loading magazine of the SBZ 625/13 profile machining centre can be loaded with up to 10 profiles between 500 mm and 7,500 mm in length. The machine is equipped with 8 transport belts as standard (with the option for more). The ergonomic loading height of 910 mm makes it easy for operators to load profiles.

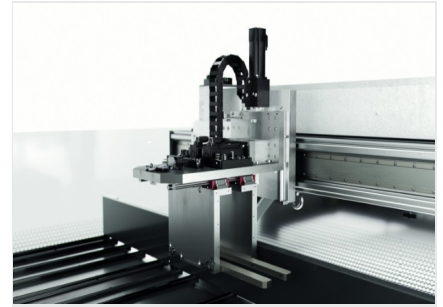

Parallel external gripper

The external gripper system uses a linear servo drive to move profile cross-sections into the exact machining position as quickly as possible. The parallel external gripper also has a programmable digital setting for the clamping jaw pressure.

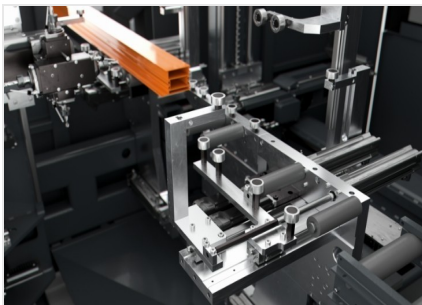

Profile clamping

Equipped with two clamping towers in the infeed and outfeed, each with 200 mm travel for profile support, the SBZ 625/13 profile machining centre boasts innovative clamping technology. A large number of horizontal and vertical clamps guarantee optimum profile clamping at all times, from infeed to outfeed.

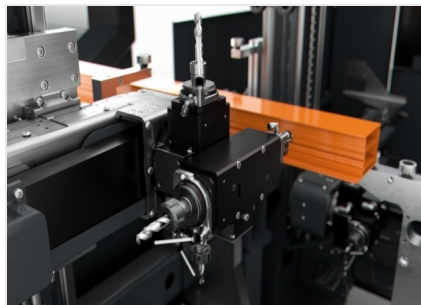

Routing unit machining station

Parallel machining reimagined: one machining tower at the front and one at the rear, each of which can be moved in 4 axes, enables simultaneous machining of the profile. With up to 8 tools on 4 water-cooled routing spindles and a rotation angle of 270°, the SBZ 625/13 profile machining centre is ideally equipped for routing aluminium. Simultaneous machining on the bar makes the process more efficient.



Intermediate buffer

The combination of an additional parallel gripper and a buffer section of up to 7,500 mm allows the machining process to be separated. The intermediate buffer allows profiles to be cut at the same time as holes are being drilled and milled in the machining station.



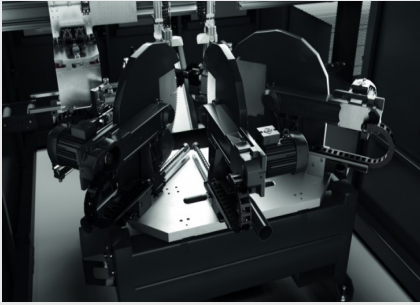

Saw unit

The linear sawing unit consists of 3 saws with a saw blade diameter of 550 mm and a drive power of 2.2 kW. Profile cross-sections of 185 x 150 mm or 185 x 230 mm can be sawn and separating cuts of 45°, 90° and 135° can be made. The plate clamps secure the workpiece with absolute reliability and ensure trouble-free profile cutting. The saw's fixed cutting angle enables high cutting speeds.

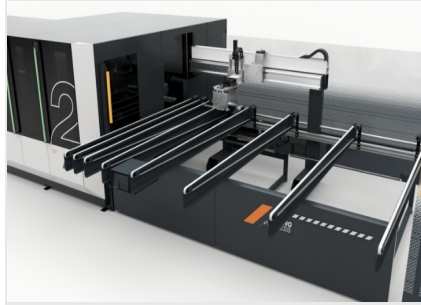

Outfeed conveyor

Using conveyor belts to feed out profiles up to 7,500 mm in length protects surfaces when handling profiles.

SBZ 625/13 / MACHINING CENTRES