

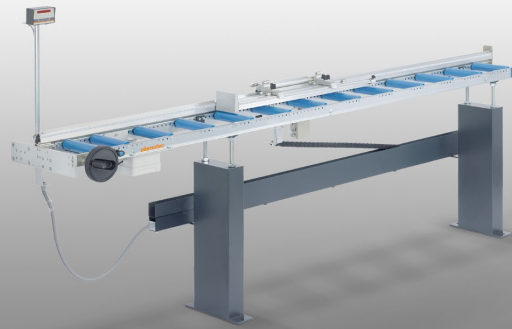

### MMS200

Length stop and measuring systems



- For cutting aluminium profiles to length accurately
- For mounting on all single-head saws (right-hand side)
- Stop carriage can be folded back for positioning of profiles
- Automatic retraction unit: No re-cutting by the saw blade (option)
- Patented rail and carriage system
- Length stop and measuring system with sliding stop and difference scale for quick and accurate adjustment

#### Length variants

- 3.000 mm
- 4.500 mm
- 6.000 mm
- Special lengths on request
- Variant for left-hand attachment on request

#### MMS 200 with E 111

See MMS 200, however:

- Digital display E 111



**Stop and measurement system MMS 200**



**Stop and measurement system MMS 200**



**Stop and measuring system MMS 200**





### MMS 200 / LENGTH STOP AND MEASURING SYSTEMS

---

- Accurate dimension adjustment using digital display
- Switching from absolute dimensions to chain dimensions
- Actual values of the display are stored when mains is switched off
- Quick read-out from the digital display. Resolution 0.1 mm
- Power supply 230 V, 1~, 50/60 Hz
- Switching between mm/inches
- Input of any desired reference value by means of front keypad