



DG102P

Double mitre-saws



Electronic twin-head cutting-off machine with automatic traverse of the moving cutting head powered by brushless motor with numerical control system. Pneumatic control of the angular setting from 90° to 22°30' (external) in two fixed positions or with optional mechanic adjustment of intermediate angles. Hydro-pneumatic blade feed.



Profile clamping

Reliable, precise profile clamping using two horizontal clamping cylinders. If vertical clamping is required, this is carried out with a special horizontal clamping system. A manually positionable additional clamp holds the remaining piece during cutting.



Protective hoods for sawing units

Two automatic protective hoods on the sawing unit protect the processing area. They are made of scratch-resistant polycarbonate and are opened and closed automatically according to the cutting cycles.



Control system

The pedestal mounted control panel is connected to the machine bed and can be positioned individually. The saw has the proven elumatec HMI with 7-inch touchscreen display. Single cuts and automatic mode with cutting lists are possible.



Loading and unloading

The double mitre saw has a roller conveyor on the movable saw unit for standard loading and unloading. As an option, an additional clamping device for clamping the remaining bar can be installed on the roller conveyor. An optional device for measuring the profile height enables the automatic correction of the cutting dimension according to the actual dimensions of the profile.



Intermediate tilting adjustment

The standard version allows performing cuts at 45° and 22°30' by mechanically presetting the end stops. An optional system is provided for tilting manual adjustment of cutting units to any intermediate angles by means of a manual handwheel, which is particularly useful when performing out-of-square cuts.





DG 102P / DOUBLE MITRE-SAWS

LAYOUT

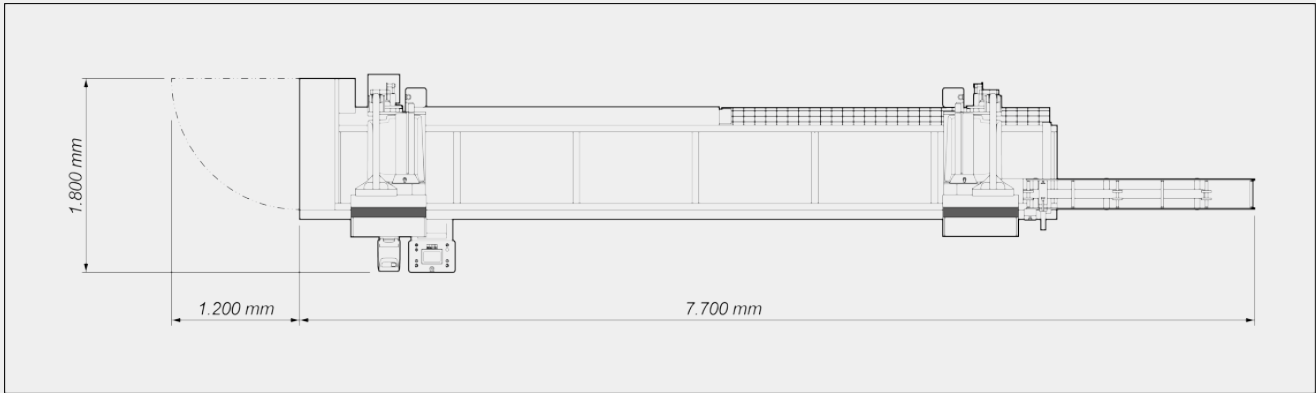

The overall dimensions may vary depending on the product configuration.

MACHINE CHARACTERISTICS

| | |
|---|--------------|
| Electronic control of the X axis | ● |
| X axis positioning speed (m/min) | 25 |
| Mobile head position reading with absolute magnetic strip direct measuring system | ● |
| Pneumatic head tilting | ● |
| External tilting | 45° / 22°30' |
| Mechanic adjustment of intermediate angles with digital display of the position | ● |
| Hydropneumatic blade feed | ● |
| Adjustable blade feed rate | ● |
| Cutting capacity (mm) | 5.000 |
| Carbide sawblade | 2 |
| Saw blade diameter (mm) | 550 |
| Saw blade motor power (kW) | 2,2 |
| Electronic profile thickness gauge | ● |



CUTTING DIAGRAM



CUTTING UNIT TILTING

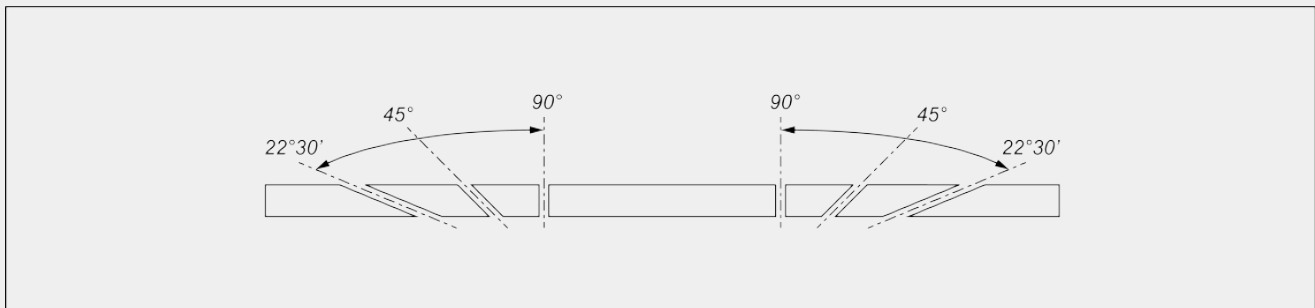

Mechanical adjustment of intermediate angles

SAFETY DEVICES AND PROTECTIONS

Pneumatically-operated front local protection ●

PROFILE POSITIONING AND CLAMPING

- Pair of horizontal pneumatic clamps with "low pressure" device ●
- Pair of horizontal vertical vices ○
- Pair of additional horizontal clamps ○
- Manually positioned profile intermediate supports 1
- Roller conveyor on mobile head (mm) 2.000
- Additional vice for profile support on roller conveyor ●



LUBRICATION AND SUCTION

| | |
|---|---|
| Minimal oil diffusion lubrication system | ● |
| Preparation for automatic start-up of external exhauster | ● |
| Swarf and short cuts extractable drawers without scraper system for swarf removal | 6 |
| Dredging system for swarf discharge | ○ |
| Swarf and short cuts extractable drawers with scraper system for swarf removal | 2 |

FUNCTIONS

| | |
|---|---|
| Perform single cuts | ● |
| Execution of intermediate angles cuts | ● |
| Execution of cyclical cuts from cutting lists | ● |
| Extended cuts, short cuts, angle cuts functionality | ● |
| Semi-automatic cut function (thrust cut) | ● |
| Cutting lists import (.dgc format) | ● |

Included ● Available ○